



## PRESSURE BRAND CAST STEEL GLOBE VALVE ND 40

### PRODUCT DESCRIPTION

- **Product** : 'PRESSURE' Cast Steel Globe Valve
- **Product Standard** : BS 5160
- **Pressure / Class / Rating** : PN 40
- **Body Material cum Standard** : CCS (ASTM A216 Gr.WCB)
- **Description** : Bolted Bonnet, OS & Yoke Type, Rising Stem
- **Type of Seat** : Renewable seat
- **Type of Disc** : Renewable disc
- **Trim** : SS AISI-410
- **Gland Packing** : Expanded Pure Flexible Graphite
- **Ends** : Flanges as per BS 4504 Part-1 / DIN 2545 RF c

HSN 84818030

### APPLICATION

Water	Oil	Steam
-------	-----	-------

### TESTING & CERTIFICATION

- **Body Test Pressure** : 76 Bar g (1100 Psig) Hyd.
- **Seat & Back Seat Test Pressure** : 40 Bar g (580 Psig) Hyd. Maximum
- **Working Temperature** : 400°C
- Test Certificate furnished with every supply.

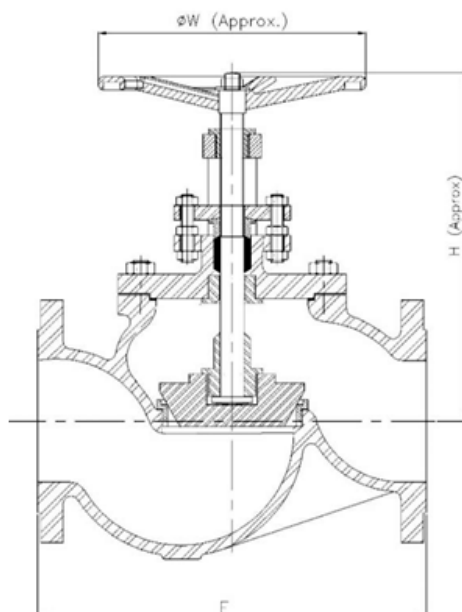

**Reg. Office** : 9, Amar Asha Society, Nr. Ramvadi Bus Stop, Isanpur, Ahmedabad-382443. Gujarat, India. **Ph.** : +91 7490034801, 9824334801

**Factory & Correspondence Address** : 16, Ambica Industrial Estate, Nr. Vatva Railway Over Bridge, Vatva, Ahmedabad-382440, Gujarat, India.

**Ph.** : +91 8320479614, 6354226326 **E-mail** : info@pressurevalves.in, marketing@pressurevalves.in **Web** : www.pressurevalves.in

Approved by



**MANUFACTURER OF INDUSTRIAL VALVES AND GEARS**