



PRESSURE BRAND FORGED STEEL GLOBE VALVE, CLASS-1500 (STANDARD BORE)

PRODUCT DESCRIPTION

- **Product** : PRESSURE Forged Steel Globe Valve
- **Product Standard** : conforming to BS 5352/ API 602
- **Type of Pattern** : Standard Bore
- **Pressure/Class /Rating** : Class-800
- **Body Material cum standard** : FCS (A 105)/F11/F22/F304/F316
- **Product Description** : Bolted Bonnet and Welded O/S Yoke type Rising Stem
- **Type of Seat** : Renewable Seat Type of Disc : Renewable Disc
- **Trim** : Type 410
- **Fasteners** : Alloy Steel (Gr. B7/2H)
- **Gaskets** : Spiral wound SS 304/(CAF/Graphite Filled)
- **Screwed Female Ends to BSPT / NPT / Socket Welded to ANSI B16.11.**

TEST PRESSURE :

- **Shell (Hydrostatic)** : 392 kg cm²
- **Seat & Back Seat(Hydrostatic)** : 287
- **Seat (Pneumatic)** : 7kg cm²
- **Maximum Working Temperature** : 425°C



SIZES / DIMENSIONS

Size (Inches)	Size (mm)	A ±1.5	B	C ~	ØD ~	E	H
1/2	15	92	9.5	9	21.7	90	161
3/4	20	104	12.7	12.0	27.2	90	185
1	25	127	12.7	17.5	33.8	90	250
1 1/2	40	140	12.7	28	48.6	150	252

Notes : 1. Product images are for illustration purposes only. Actual product may vary.

2. Actual dimensions may change over time, due to continual design improvements. Please confirm before placing order

Reg. Office :9, Amar Asha Society, Nr. Ramvadi Bus Stop, Isanpur, Ahmedabad-382443. Gujarat, India. **Ph.** : +91 7490034801, 9824334801

Factory & Correspondence Address : 16, Ambica Industrial Estate, Nr. Vatva Railway Over Bridge, Vatva, Ahmedabad-382440, Gujarat, India.

Ph. : +91 8320479614, 6354226326 **E-mail** : info@pressurevalves.in, marketing@pressurevalves.in **Web** : www.pressurevalves.in

Approved by
NSIC
एन एस आई सी



IBR
Approved

MANUFACTURER OF INDUSTRIAL VALVES AND GEARS



PRESSURE BRAND FORGED STEEL GLOBE VALVE, CLASS-1500 (STANDARD BORE)

MATERIALS

P.No.	Name of Part	Material of Construction	Specification	Qty.
1	Body	Forged Carbon Steel/ Forged Alloy Steel/ Forged Stainless Steel	ASTM A 105/F11/F22 /F304/F316	1
2	Body Seat Ring	Stainless Steel	ASTM A276 Type 410 /304/316 / ASTM A 182 Gr. F6a	2
3	Plug/Disk (Solid)	Stainless Steel	ASTM A217 Gr. CA 15	1
4	Stem	Stainless Steel	ASTM A276 Type 410/ SS304/SS31/ ASTM A 182 Gr. F6a	1
5	Gasket	Spiral Wound S.S (Type 316) Graphite Filled	---	1
6	Bonnet	Forged Carbon Steel/ Forged Alloy Steel/ Forged Stainless Steel	ASTM A 105/F11/F22 /F304/F316	1
7	Bonnet Nut		ASTM A 194 Gr. 2H	4
8	Stud	Alloy Steel	ASTM A 193 Gr. B7	4
9	Gland Packing	Alloy Steel Non Asbestos Graphite With	---	----
10	Gland	Corrosion Inhibitor	ASTM A276 Type 410.	1
11	Gland Flange	Stainless Steel	---	
12	Eye Bolt	Carbon Steel Stainless Steel	ASTM A276 Type 410 / ASTM A 182 Gr. F6a	1
13	Nut		ASTM A194 Gr. 2H	2
14	Yoke Sleeve	Alloy Steel	BSEN 1982 AB – 1	1
15	Handwheel	Aluminium Bronze	ASTM A 536	1
16	Identification Plate	Ductile Iron	---	1
17	Check Nut	Aluminium	ASTM A 276 Type 410	1
18	Washer	Stainless Steel	---	2
19	Screw	Carbon Steel Carbon Steel	---	2

Notes : 1. Product images are for illustration purposes only. Actual product may vary.

2. Actual dimensions may change over time, due to continual design improvements. Please confirm before placing order

Reg. Office : 9, Amar Asha Society, Nr. Ramvadi Bus Stop, Isanpur, Ahmedabad-382443. Gujarat, India. **Ph. :** +91 7490034801, 9824334801

Factory & Correspondence Address : 16, Ambica Industrial Estate, Nr. Vatva Railway Over Bridge, Vatva, Ahmedabad-382440, Gujarat, India.

Ph. : +91 8320479614, 6354226326 **E-mail :** info@pressurevalves.in, marketing@pressurevalves.in **Web :** www.pressurevalves.in

Approved by



MANUFACTURER OF INDUSTRIAL VALVES AND GEARS



PRESSURE BRAND FORGED STEEL GLOBE VALVE, CLASS-1500 (STANDARD BORE)

Notes : 1. Product images are for illustration purposes only. Actual product may vary.
2. Actual dimensions may change over time, due to continual design improvements. Please confirm before placing order

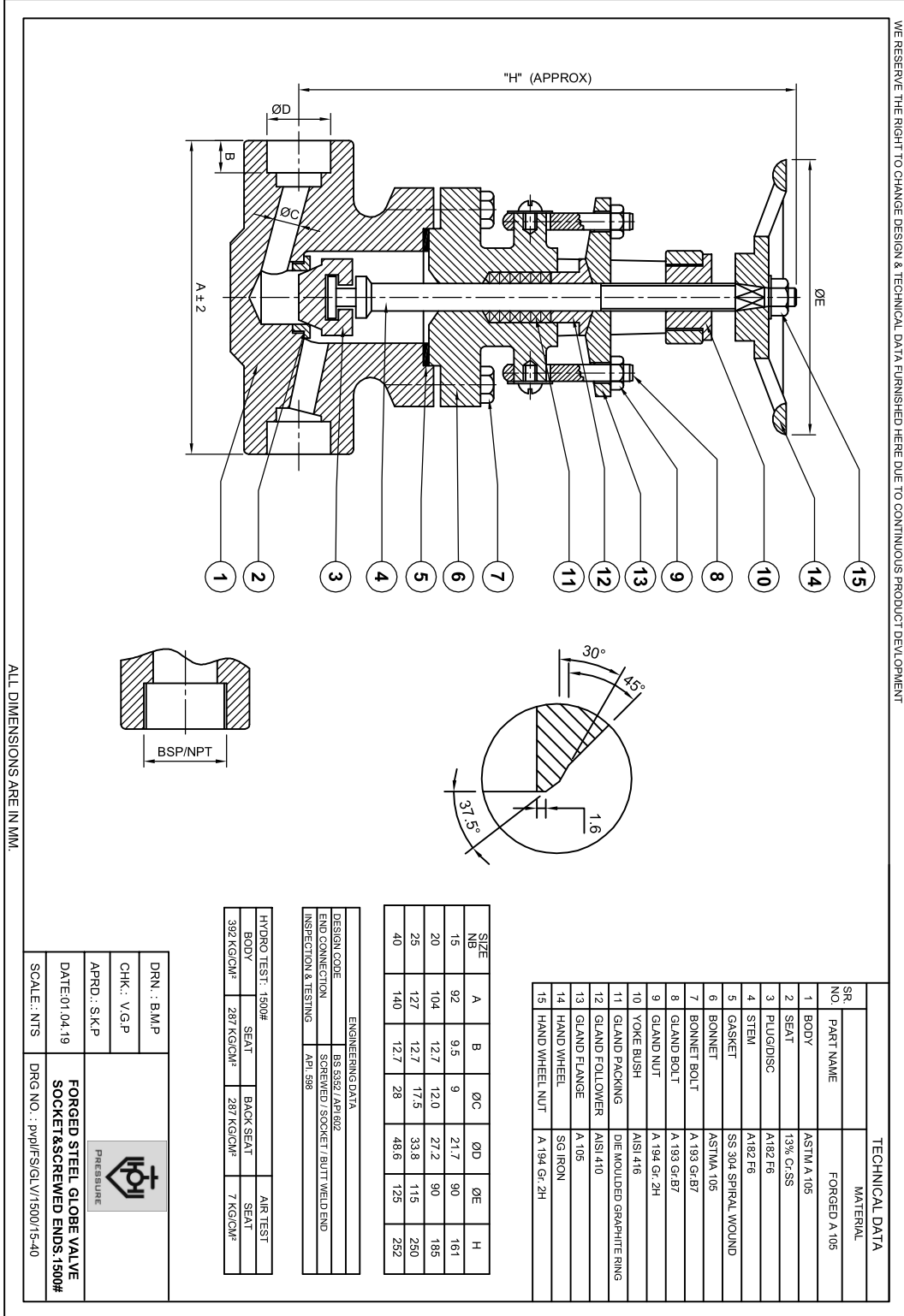

Reg. Office : 9, Amar Asha Society, Nr. Ramvadi Bus Stop, Isanpur, Ahmedabad-382443. Gujarat, India. Ph. : +91 7490034801, 9824334801
 Factory & Correspondence Address : 16, Ambica Industrial Estate, Nr. Vatva Railway Over Bridge, Vatva, Ahmedabad-382440, Gujarat, India.
 Ph. : +91 8320479614, 6354226326 E-mail : info@pressurevalves.in, marketing@pressurevalves.in Web : www.pressurevalves.in